

窪田八重子 作 (PL-20)

材料

- 1) 頭 2.5% 栴紙 (黒) 正形 (1枚)
- 2) 楊 2% x 3% 鹿の子 2% 正形 (各枚?)
- 3) 着物 15% 正形 友禪紙 (1枚)
- 4) 帯 15% " " (1枚)
- 5) 長褙子 9% " " (1枚)
- 6) 袴 7.0% x 2% (白、ヒョウ、赤色) (3枚)
- 7) 木履^{木履} 6% 正形 新紙紙 (1枚)
- 1) 首 5% " 積紙 (白) (1枚)
- 色紙 下色紙 他 水引 少。

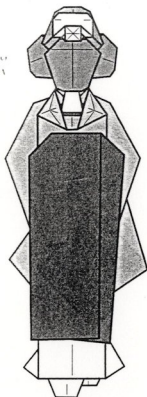

1) 頭 2.5%

鶴の基本形ⅡF

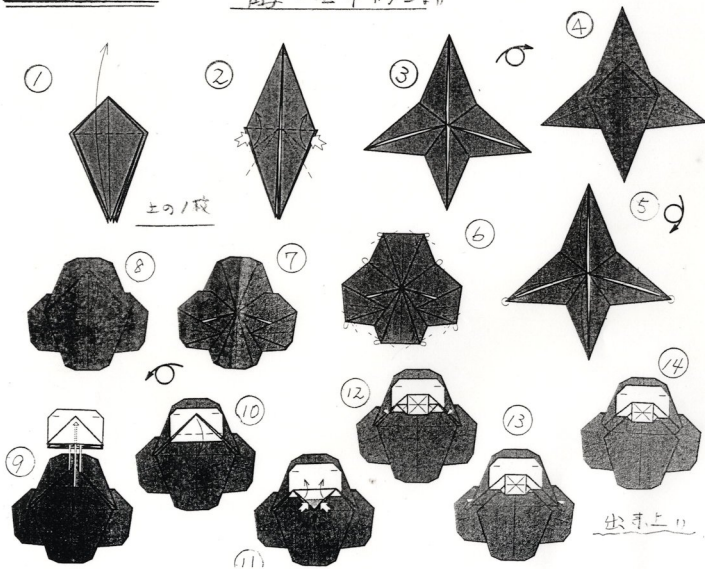

出来上り

3) 長襦袢の裾 (9%正柄)

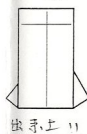
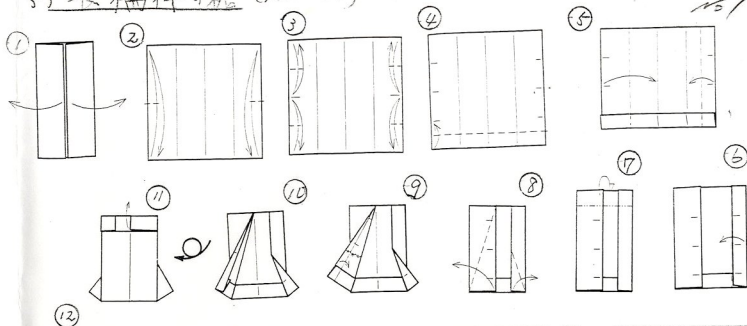

4) 帯

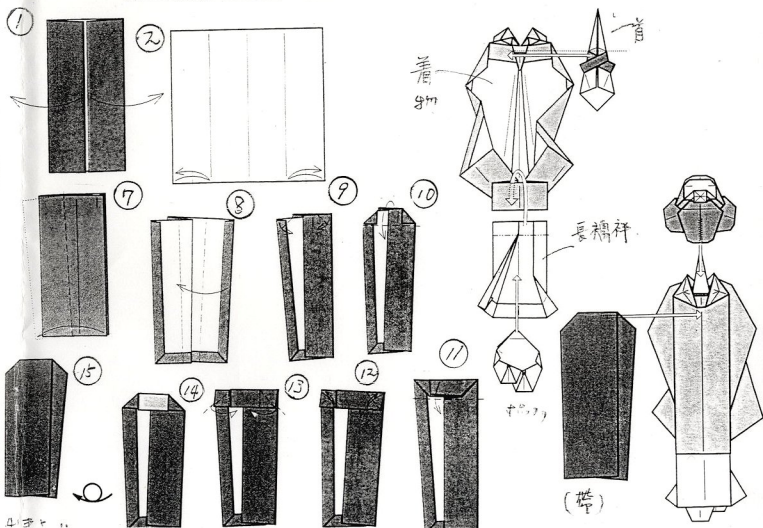
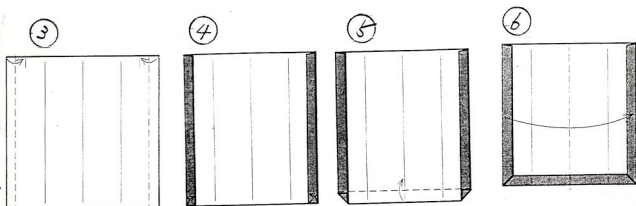

2) くし 鹿の子

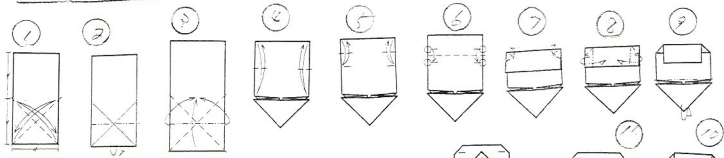

6) 衿 $2\frac{1}{2} \times 7\frac{1}{2}$ 球
(白、ヒツ、赤)

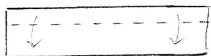

くし 鹿の子
頭に着込

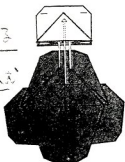

出来上り

8) 首 (5% 正方形)

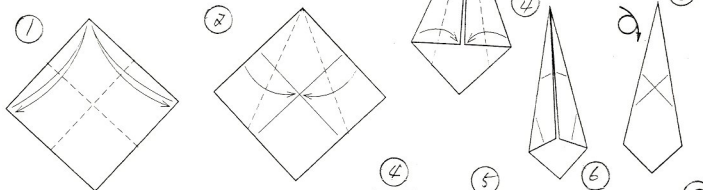

5) 着物 $15\frac{1}{2} \times 16\frac{1}{2}$

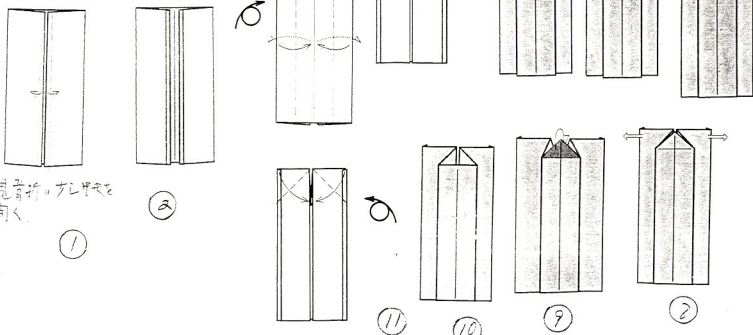

鏡首折、ナレ甲と
同く

7) 木履 (浮きく))

No 2

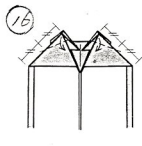
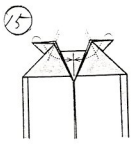
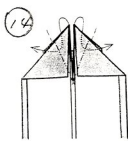
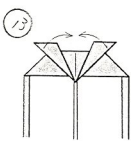
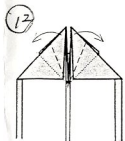
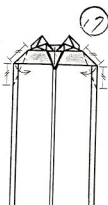
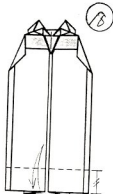
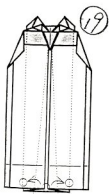
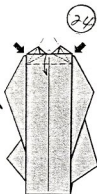
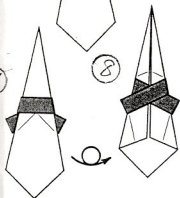
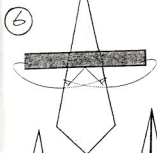
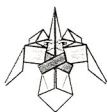
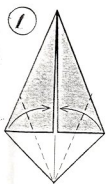

長福祥の裾廻し 9% 正方形

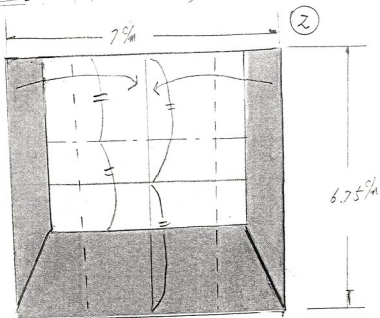
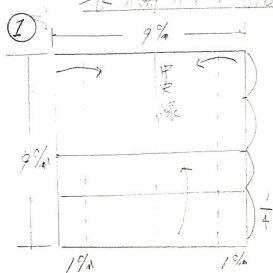

⑤



出束上り

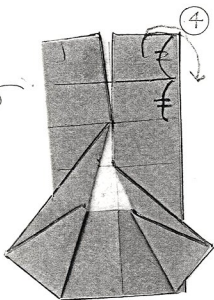

③

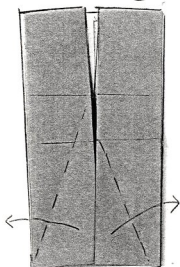

木履(ホッフリ) 6% 正方形

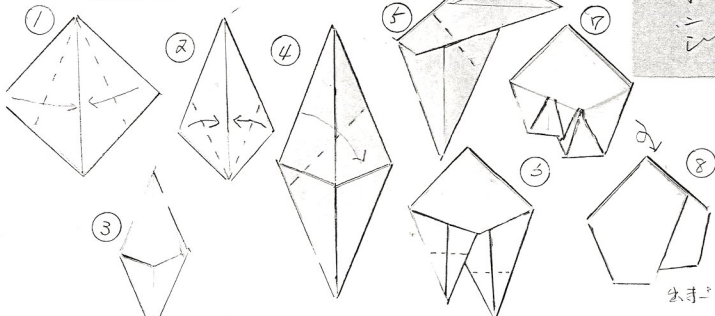

出束上り

木箱(くし) $2\% \times 3\%$

No. 3

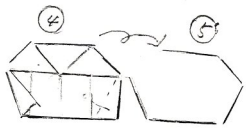
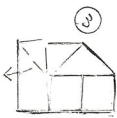
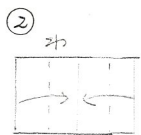
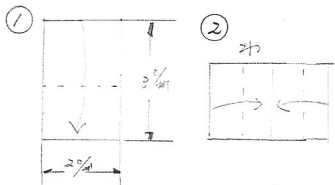

鹿の子 $2\% \text{ 正方形}$

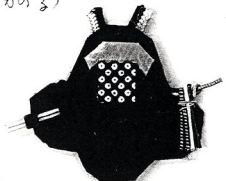
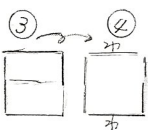
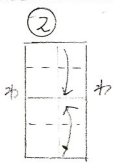
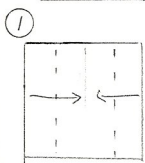

頭部の飾りの
水引他

頭部



首と半袴
(白ヒツシ)

H. 15. 10. 6. (月)

田中静子