

材料内訳 10cm

一、小野道風 本体 互裨紙 7.5% 角	1枚	二、蛙 楮紙 10.5%角	1枚
" 頭 楮紙(黒) 7.5%角	1枚	三、傘 互裨紙 15%角	1枚
" 顔 " (白) ^{9%} 1.5x3.5%	1枚	" 柄 10%角	1本
" 衿 2% ^白 x7.5% ^{柄物}	1枚	" 頭部 楮紙 3.5%角	1枚
" 帽子 2.5%x3.5%	1枚	" 紐 9%	1本
" 袴 10% ^白 x5% ^{互裨紙}	1枚	" ストピー 2%x3%	1枚
" 足 3%角	2枚		
" ストピー 3%x4%	1枚	下色紙、フリット柄 白紙	1枚

① (袴) 10%^白x5%^{互裨紙} (1枚)

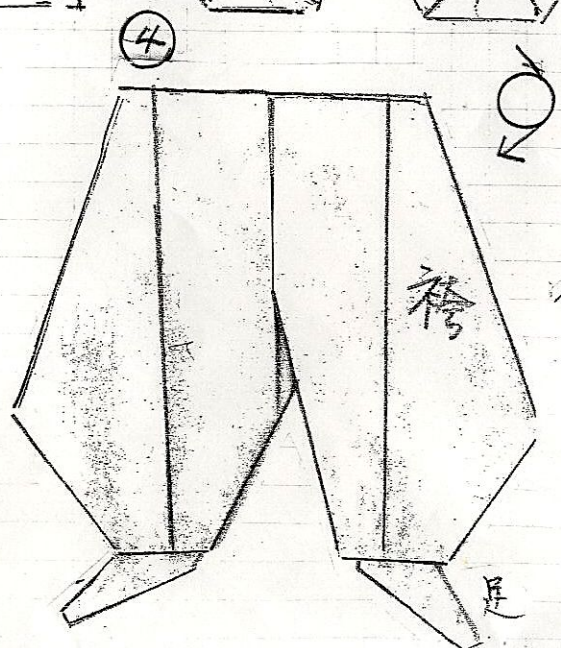
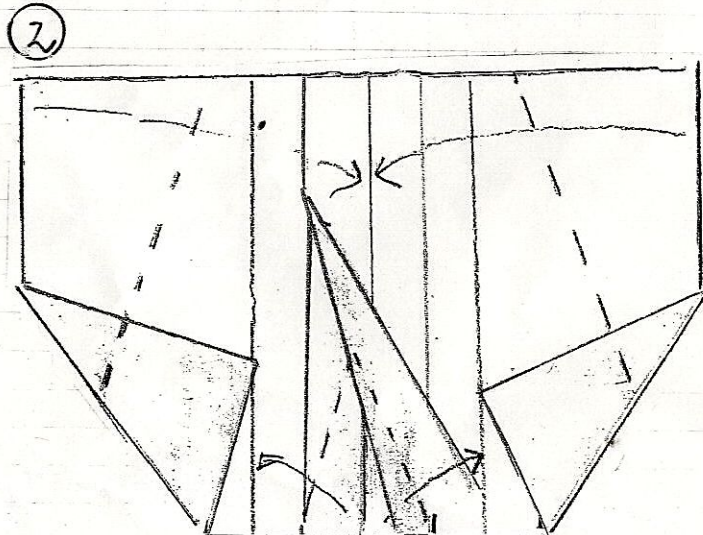
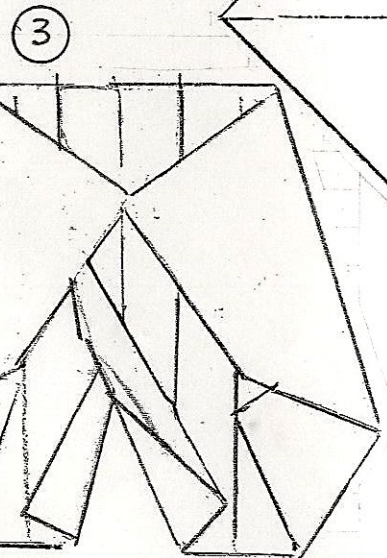
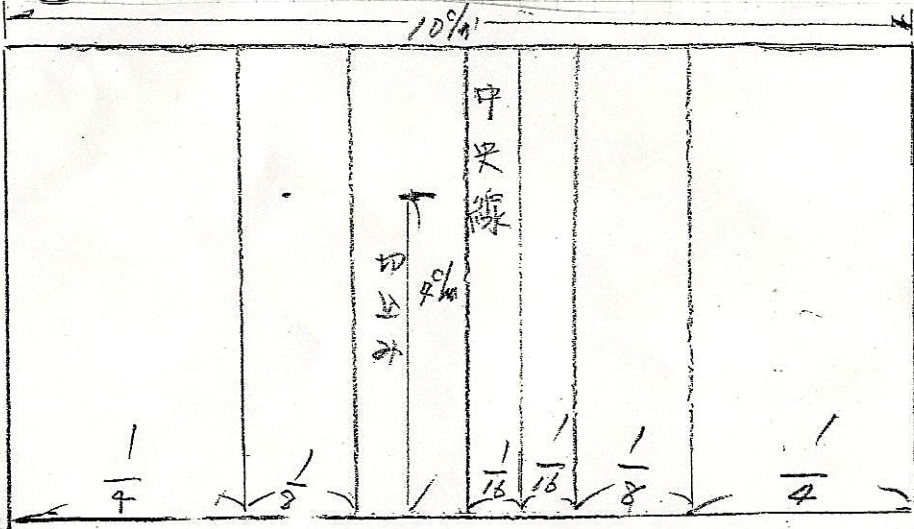

本体

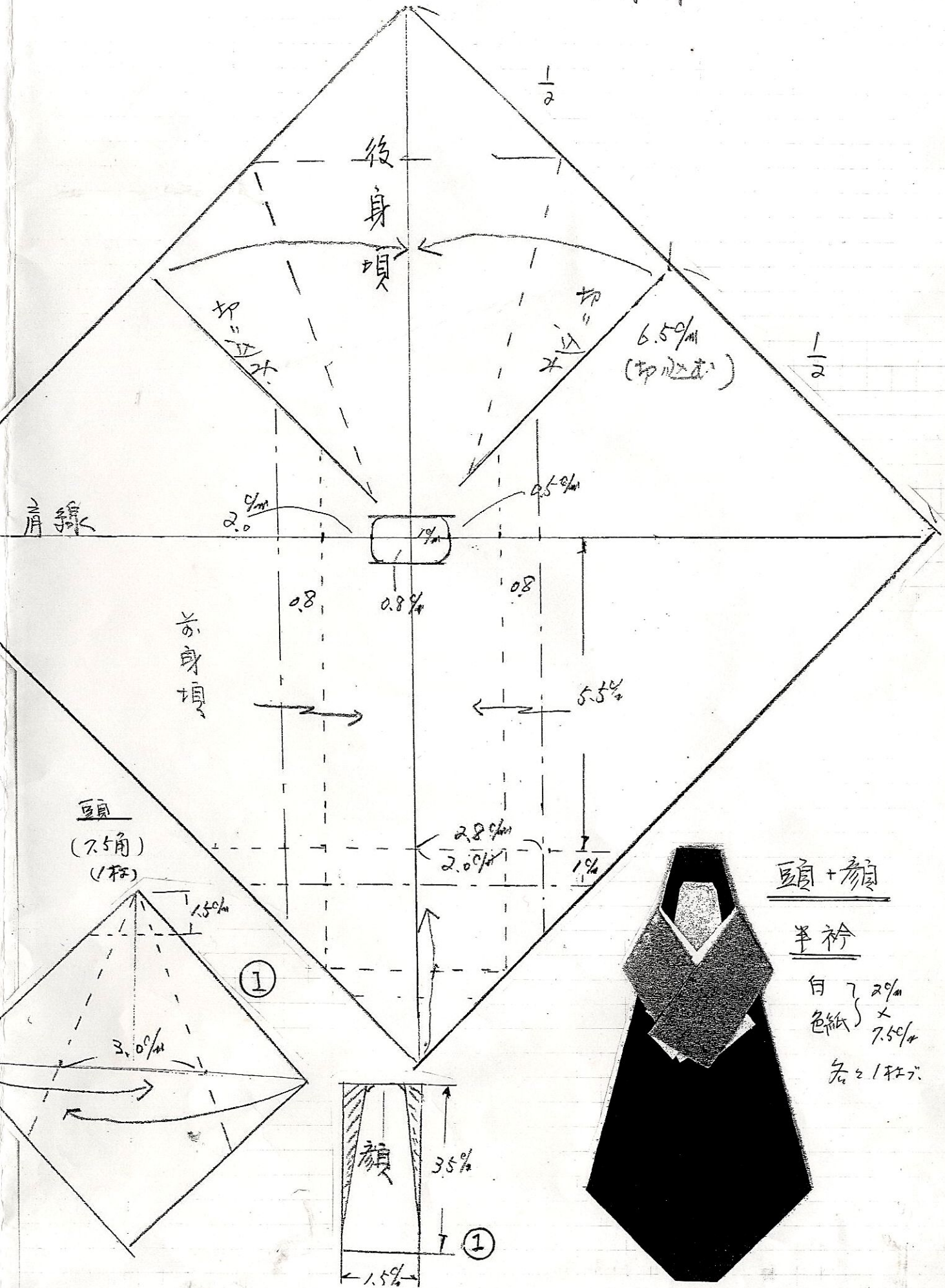

頭+顔

半衿

白紙 } 2cm
 x 7.5cm
 各2枚

足 3%_m 角 (2枚)

(小野道凡)

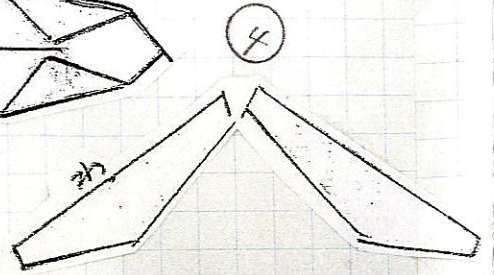
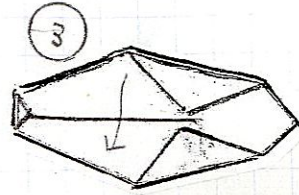
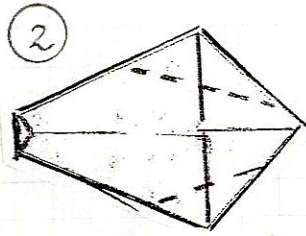
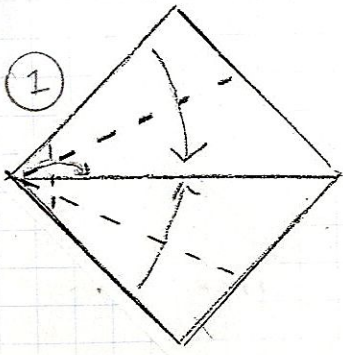

帽子

2.5%_m x 3.5%_m (175)

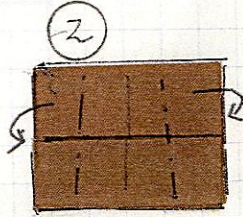
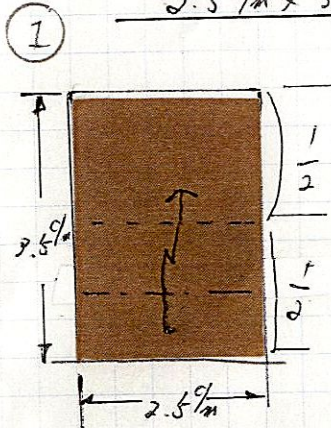

(袴 + 足)

半衿

白 柄物

2%_m x 7.5%_m (175)

傘の型紙

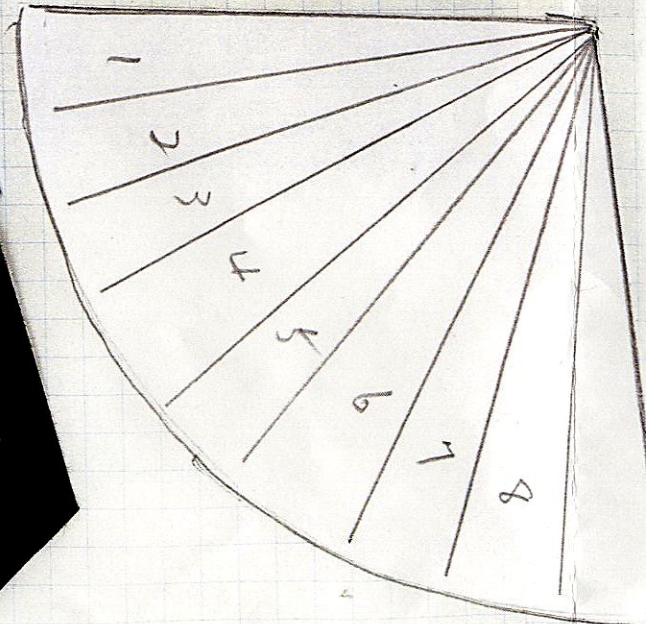
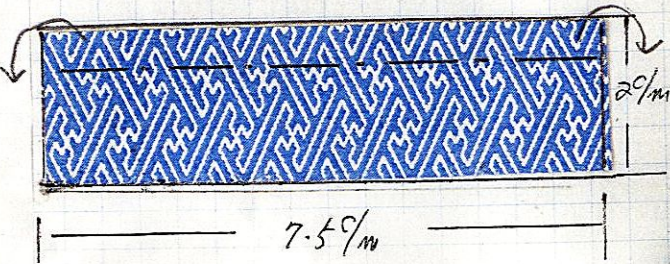
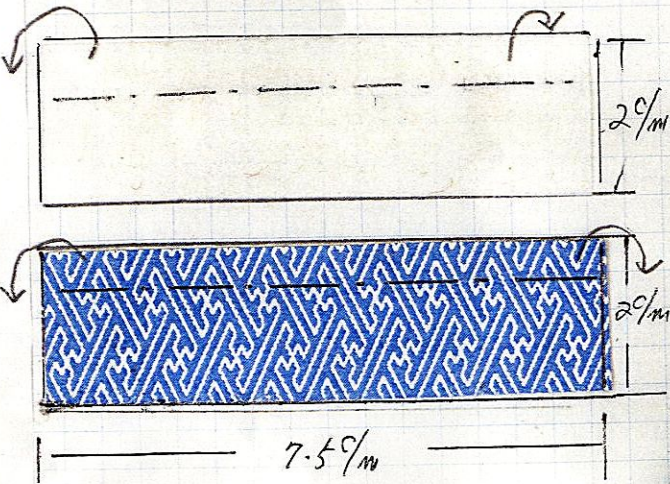



1423.10.5(7)

田中静子 

傘 15% 用 1枚

柄 1本 2% 用

トシホ 3.5% 用 (1枚)

結ぶ紐 7% 用 (1本)

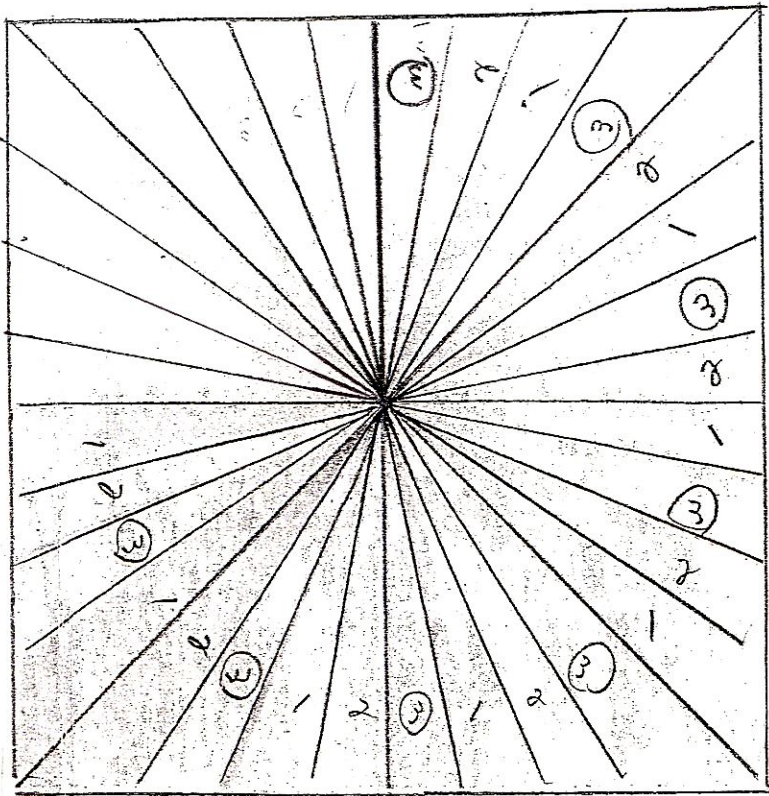

(*) 折線を口まみ作らぬ

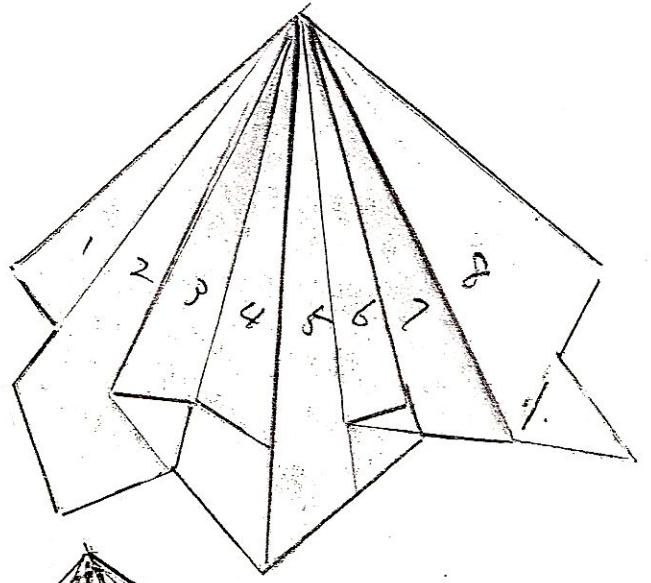

トシホ 3.5% 用 (1枚)
結ぶ紐 7% 用 (1本)

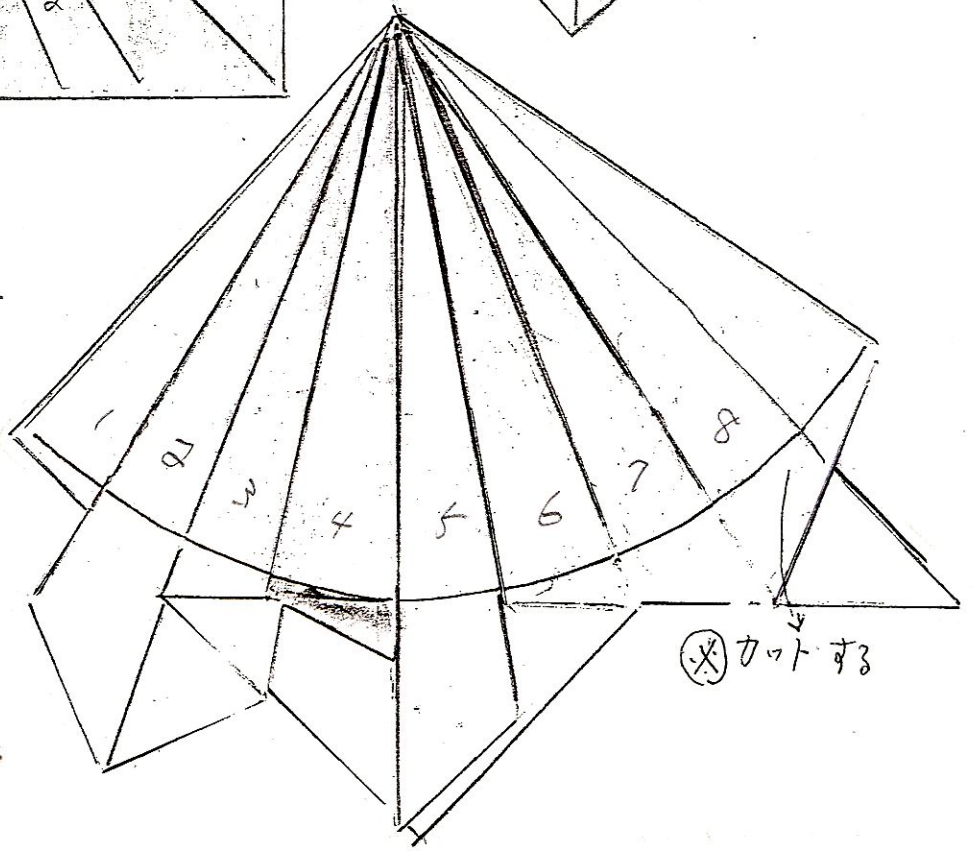

(*) カットする

傘の柄

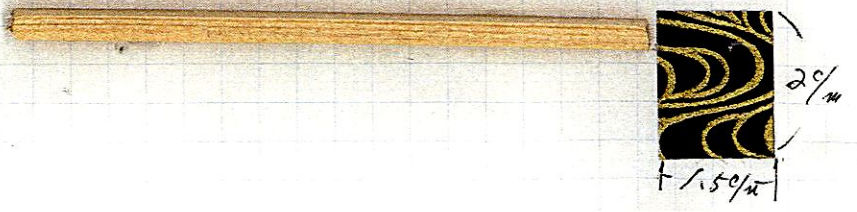
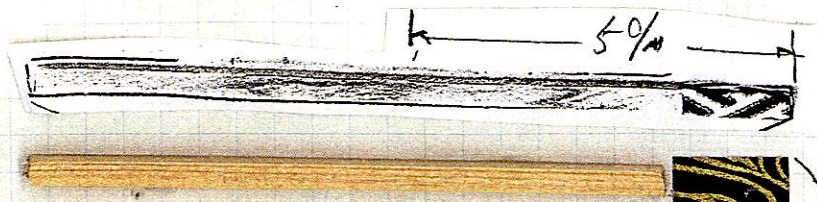

(正の基本形)

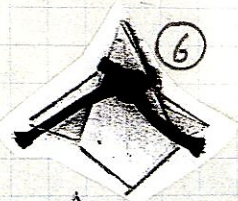
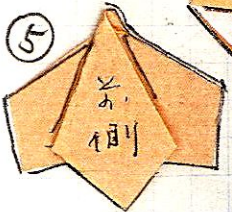
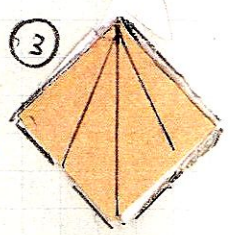
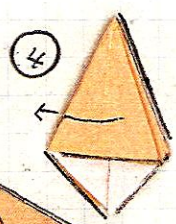
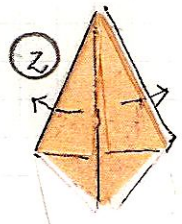
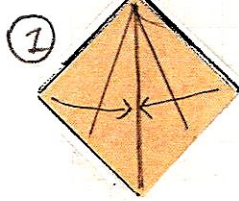

(*) 傘の上へ
貼る

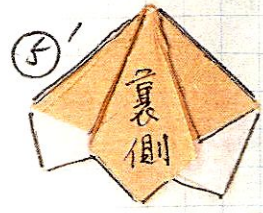

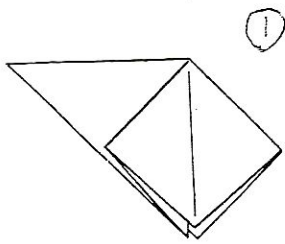

①

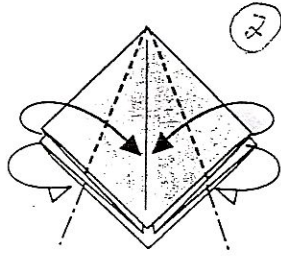

②

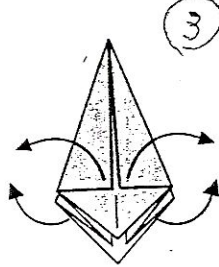

③

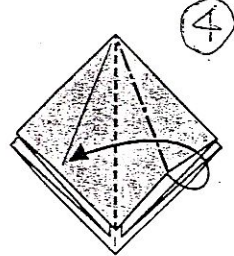

④

うちがわを
ひろげて
つぶすように
おる

正方の基本形を作る

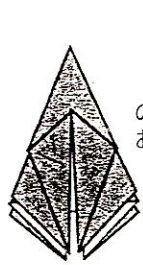

⑨
のこりも
おなじ

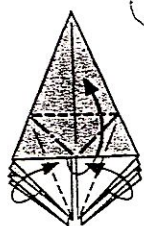

⑧

つけたおりすしを
つかって
うちがわをひろげて
つぶすようにおる

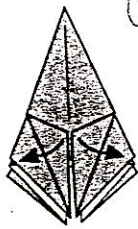

⑦

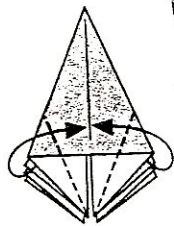

⑥

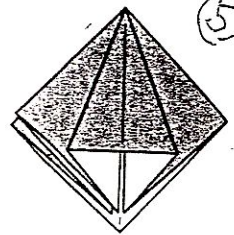

⑤

のこりも
おなじに
おる

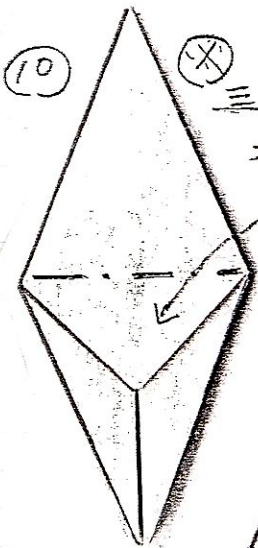

⑩

⑩

三ヶ所内部へ
折込む
一ヶ所は
裏のまゝにする

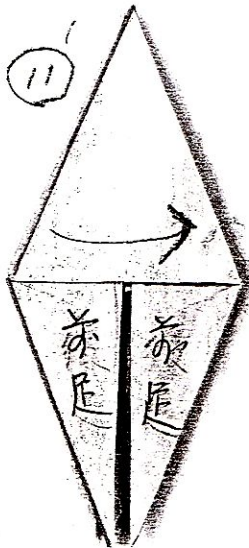

⑪

⑫

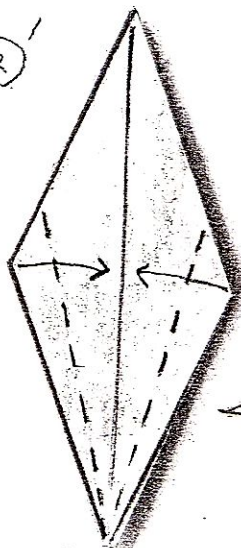

⑬

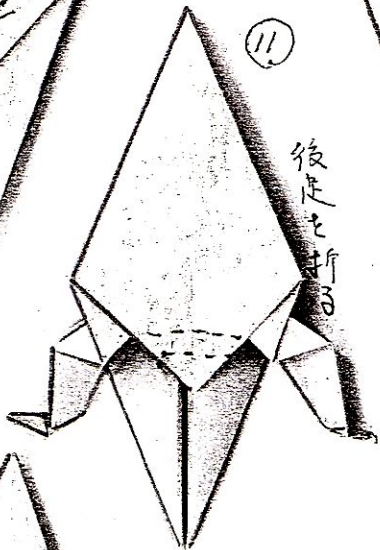
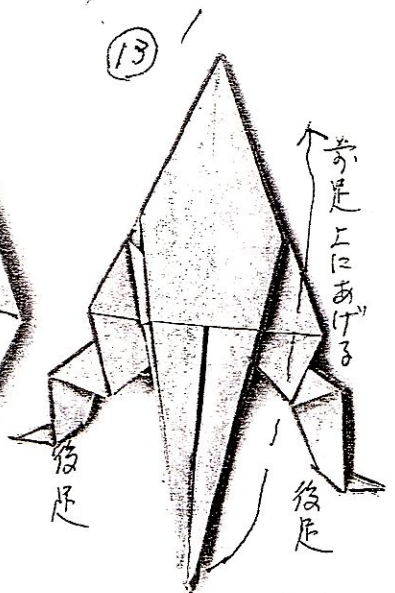

⑪

後尾を折る

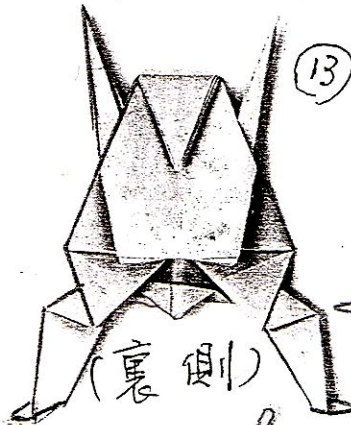

⑬

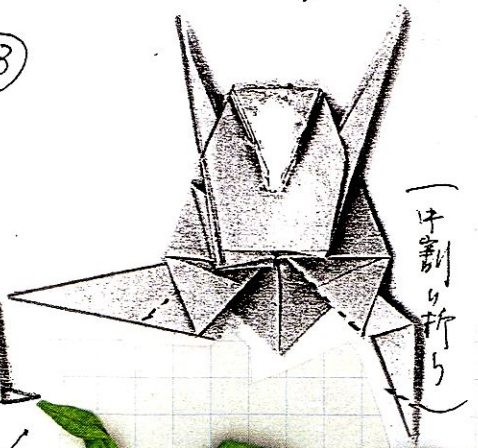

(中割り折り)

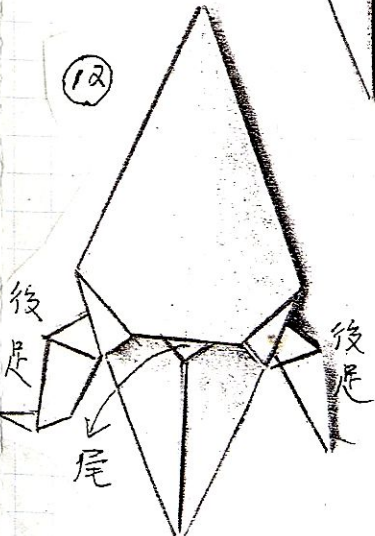

⑫

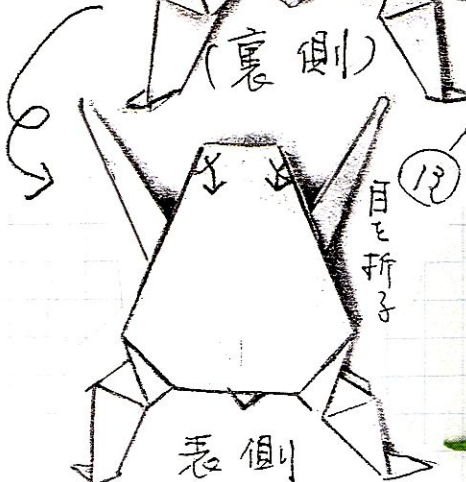

⑬

表側

