

材料内訳

① 金鐘(ベル) 奉書片面金 7.5%角 2枚	④ 柊の葉 極緑×和紙 4%角 4枚
" (布地) 高濱利恵 2.5%角長き 1枚	" 真 小川和紙 6%角 2枚
② ロウ燭 楮糸紙 (白色) 7.5%角 2枚	" " (赤色) 2%角 2枚
" 小川和紙(赤色) 2.0%角 2枚	⑤ ホイーンセウ 芭 極緑×和紙 5%角 1枚
③ 燭台 芭紙 (黄土色) 7.5%角×4%角 1枚	" " 6%角 2枚
" 友禅紙 (2.5%角×5%角) 1枚	花 7.5%角
天色紙	⑥ 雪の結晶  

金鐘(ベル) 7.5%角 高濱利恵 氏作 7.5%角

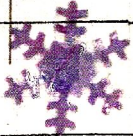
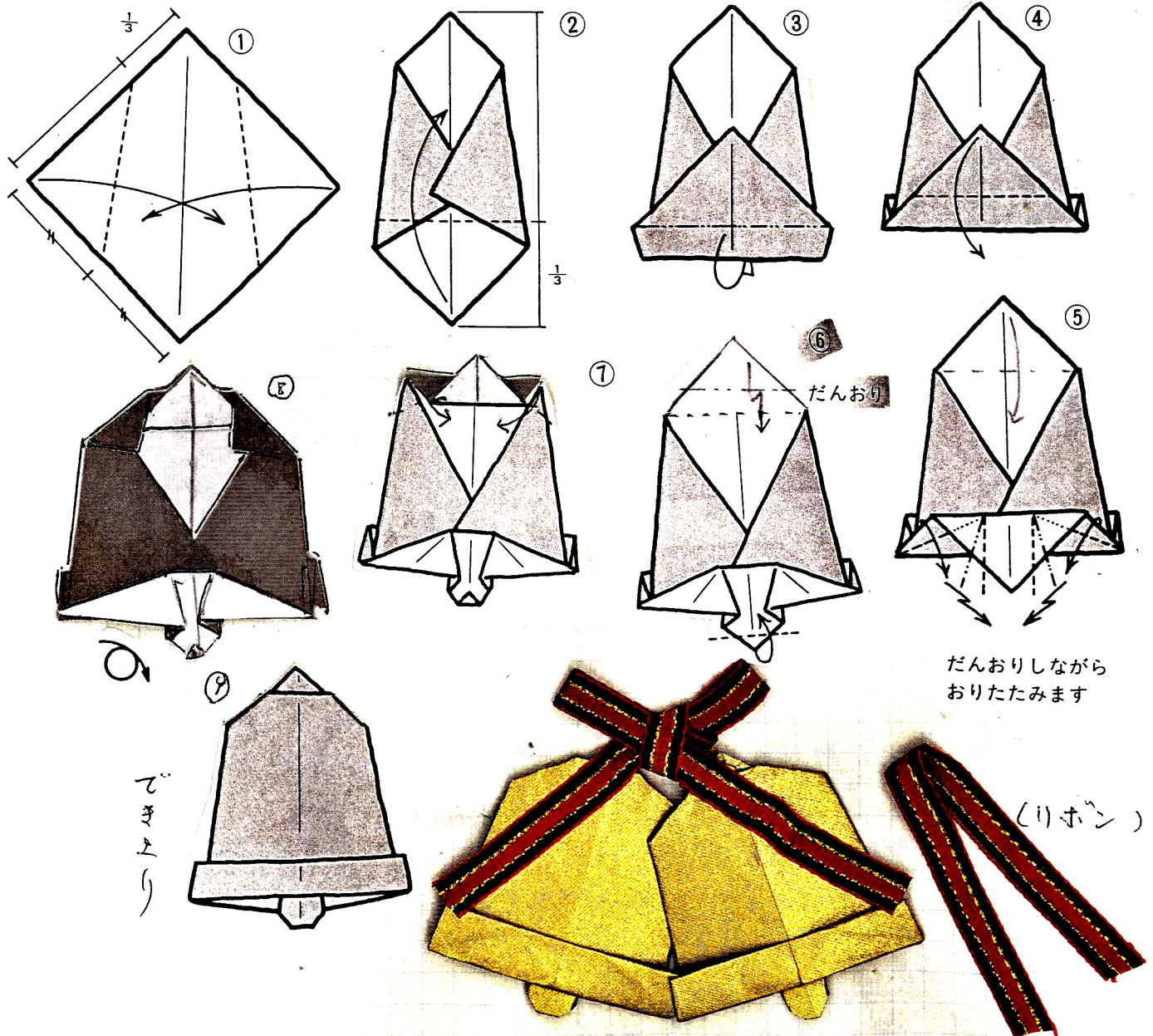

だんおりしながら
おりたみます

(リボン)

(1) (赤色) 2% = 等辺三角形

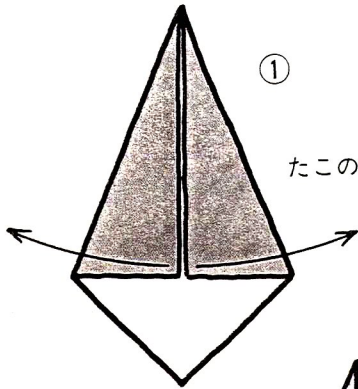

①

たこの基本形より

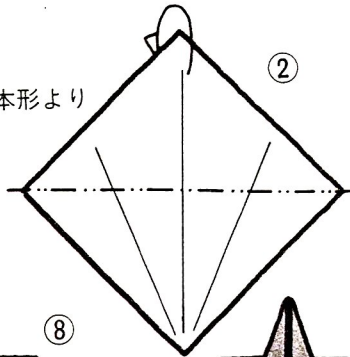

②



③

ひらいて
おりたたみます

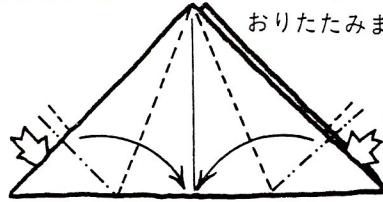

④

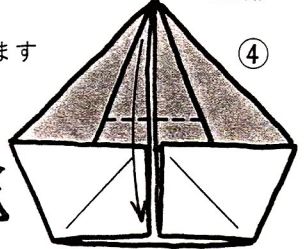

もどします

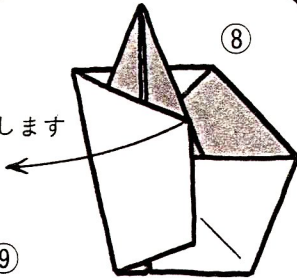

⑧

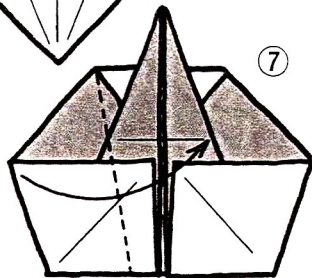

⑦

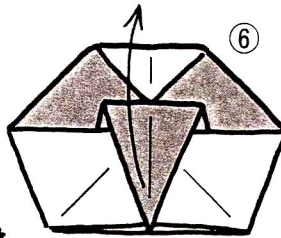

ひらきます

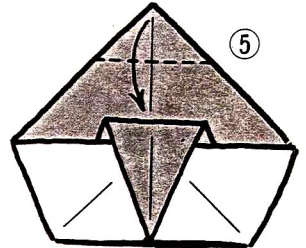

⑤

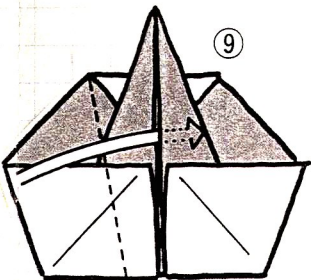

⑨

おってさしこみます

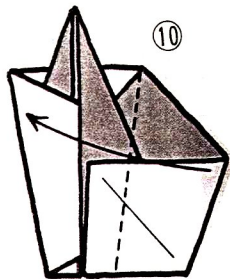

⑩

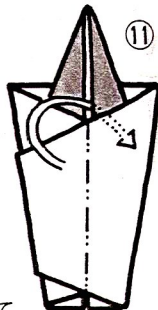

⑪

おって
さしこみます

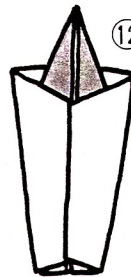

⑫

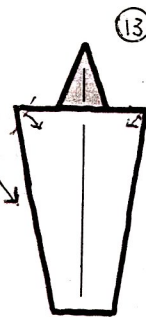

⑬

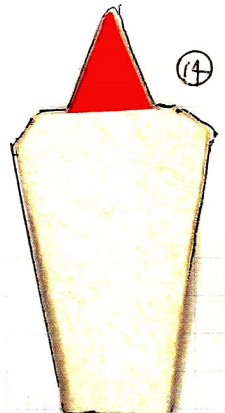

⑭

できエリ

火罫 ① (紫の-) 7.5% x 4% 1枚
火罫 ② (紫の=) 5% x 2.5% 1枚

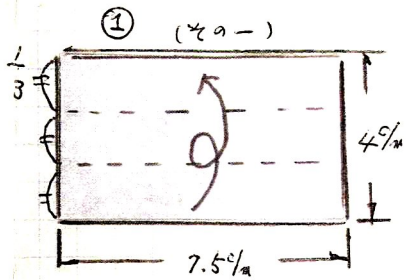

① (紫の-)

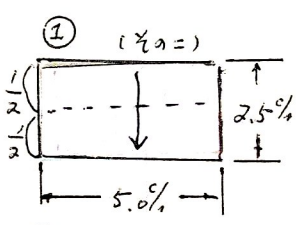

① (紫の=)



②

(わ)

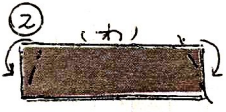

③



紫の二



④

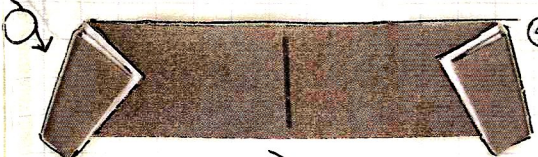

⑤

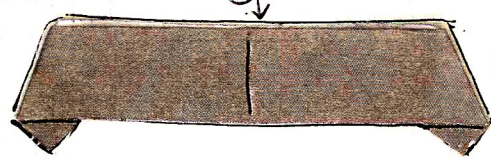

⑥

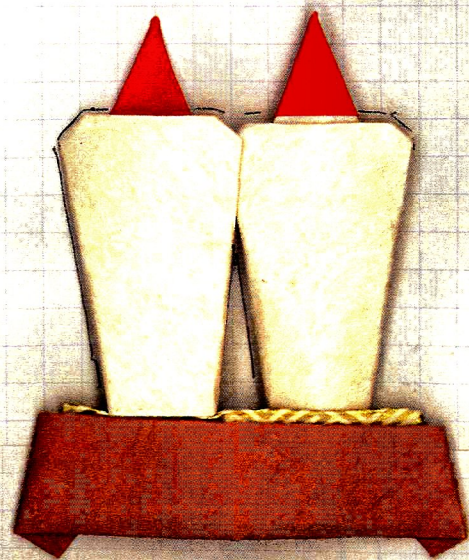

燭ら口
(紫の=)



(わ)

(紫の-)



“ の 実 6%角 (赤) 2%角 (白)

葉

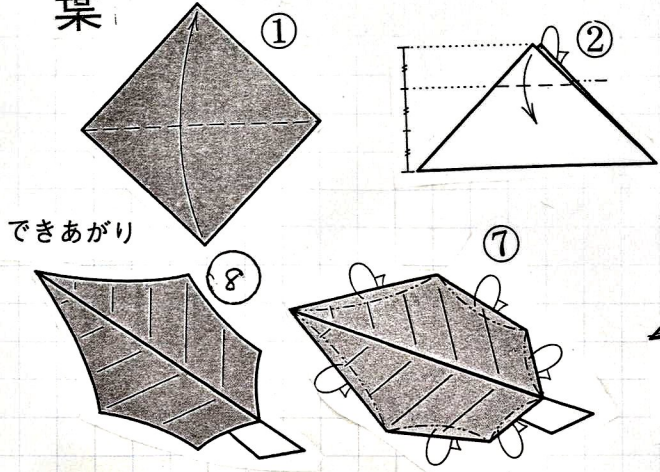

できあがり

同じものを
2枚折ります

かどをとがらせながら
葉のふちに
丸みをつけます

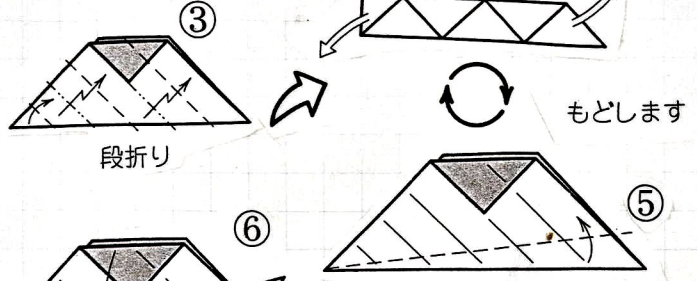

段折り

もどします

1枚だけ
折ります

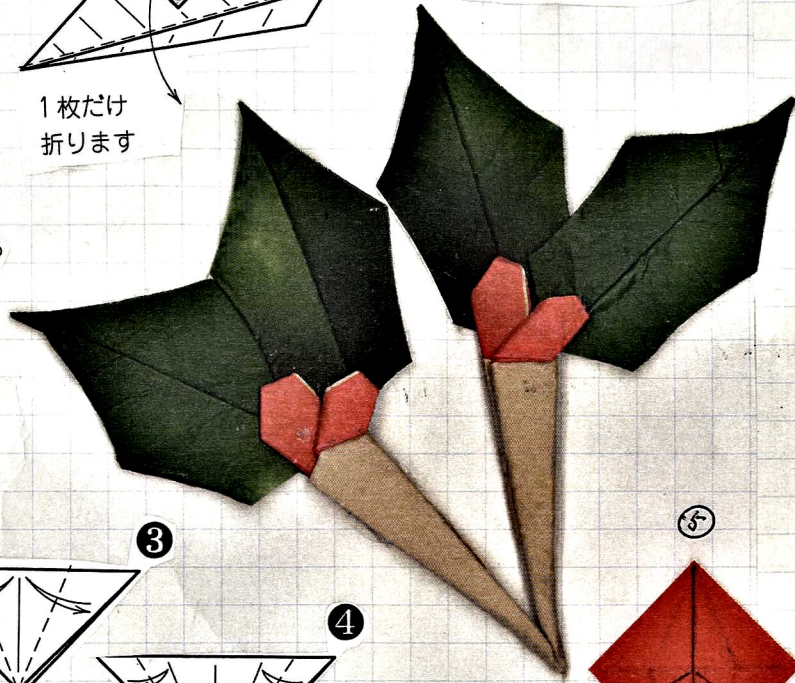

実

6%角 2%角 (赤)

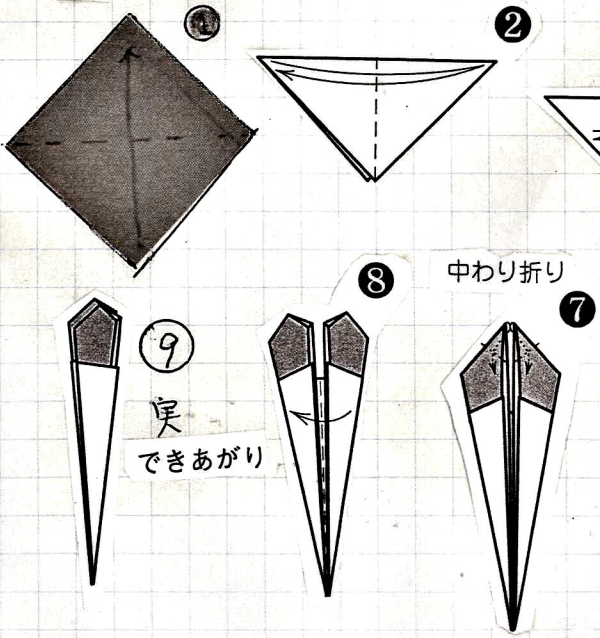

中わり折り

巻くように折ります

かぶせ折り

できあがり

できあがり

●くみあわせかた●

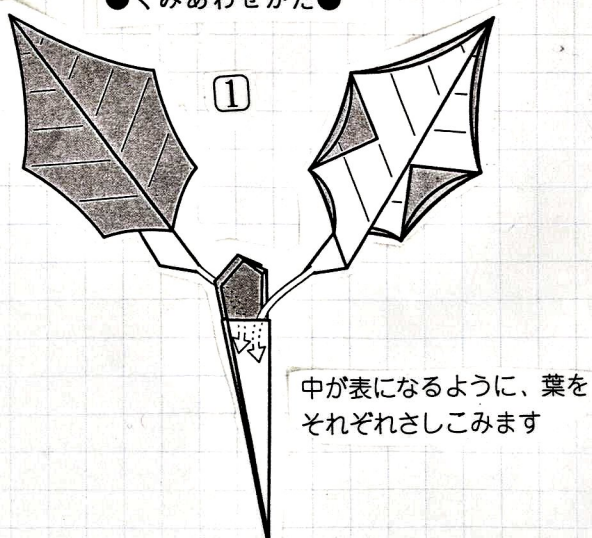

中が表になるように、葉を
それぞれさしこみます

葉と中の実を
開いて
形を整えます

使用する紙の大きさの割合
葉：実 = 2：3

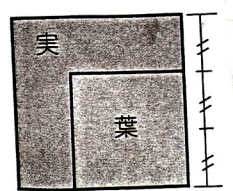

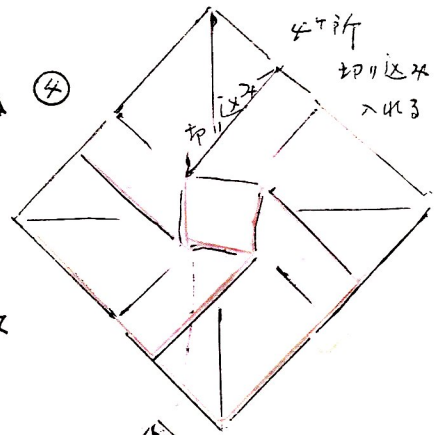
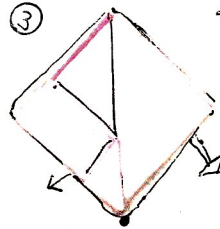
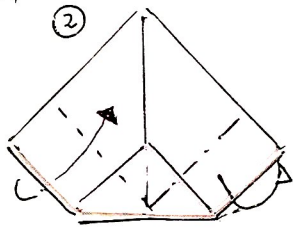
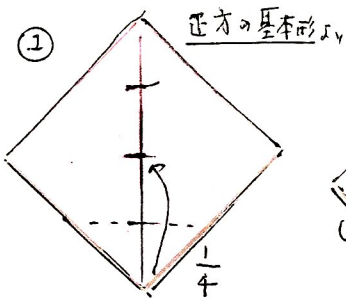

中心をねじるようにして
平らにする

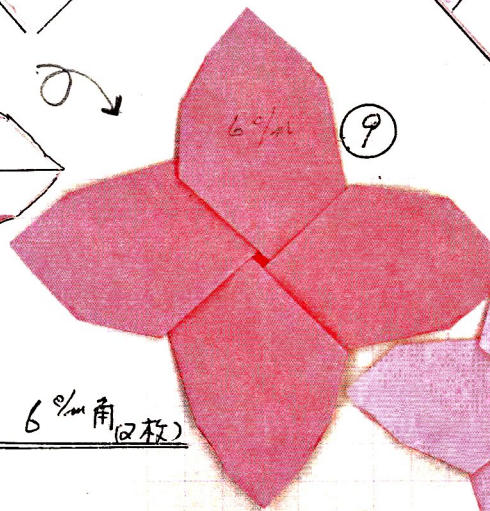
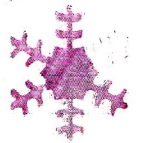
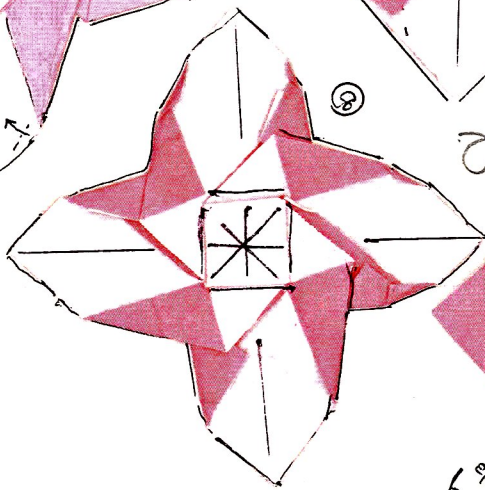
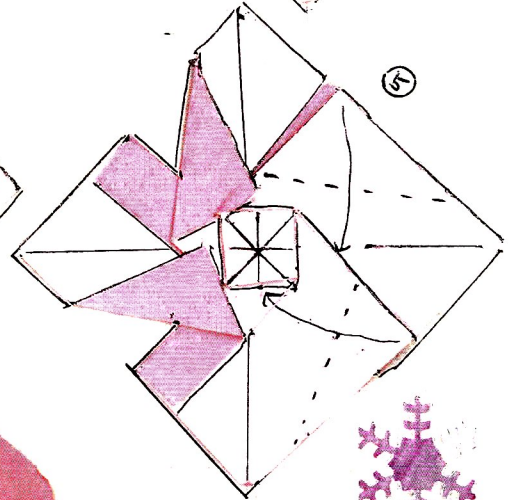
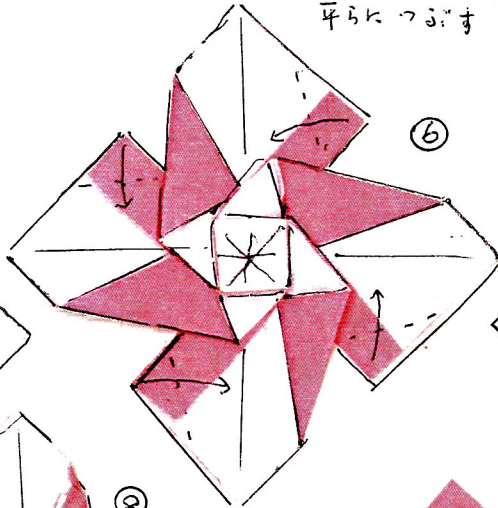
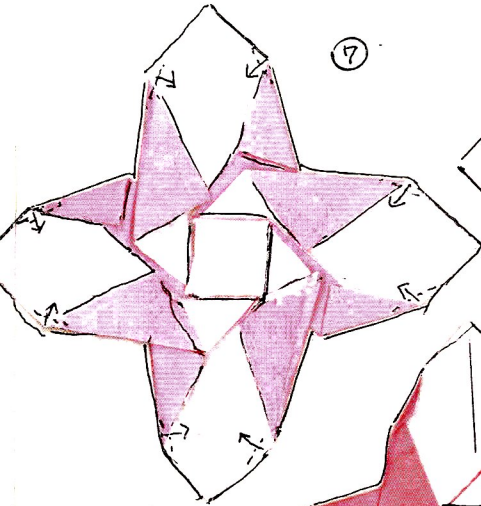

5°角 (1枚)

※ 3枚 = 1組
と作る

6°角 (2枚)

ポインセチア
* できあがり

10

※ 花
へろろ

木冬 実 (6°角)

2°角
実 (赤色)

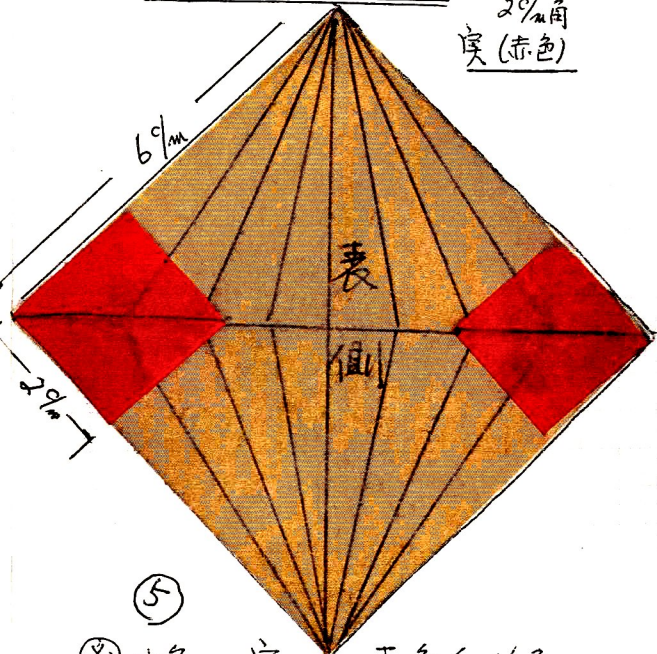

※ ポインセチア

⑤
※ 木冬の実 赤色 (2°角)
飾るごと (2枚)